



**11th Congress of the APSR
(Asian Pacific Society of Respirology)**

November 19-22, 2006 Kyoto, JAPAN

Exhibition Manual

Exhibition Secretariat

Hidero Nakatsuki

**Hongo UC Bldg. 4F, 3-35-3 Hongo Bunkyo-ku,
Tokyo, 113-0033**

FAX: +81-3-3815-2028

Email: apsr-ex@coac.co.jp

1. Exhibition Schedule

Exhibition Schedule

Day	Time	Activity
November 19	09:00-18:00	Exhibition Move in and Set up
November 20	08:30-18:00	Exhibition Open
November 21	08:30-18:00	Exhibition Open
November 22	08:30-12:00	Exhibition Open
November 22	12:00-14:00	Exhibition Move out

Booth Location

Annex Hall, 1st floor, Kyoto International Conference Hall (KICH)

<http://www.kich.or.jp/en/index.html>

Please find attached the booth layout.

Exhibitor's badge

Please inform us the number of exhibitor's badge you need by Form A-1.

We will hand over to you on November 19.

Program book

1 program book of the APSR Congress per company and 1 congress pass per booth will be available.

Both of them will be distributed to your booth on November 19.

2. Booth Size and Facilities

Type-A

9 square meters (3m x 3m)

Shell Scheme: partition walls on three sides*

*Please note that if your booth is an end booth, a side panel of aisle side will not be installed.

Color: white

Size: W3m x D3m x H2.5m

Price: 378,000 yen (tax inclusive)

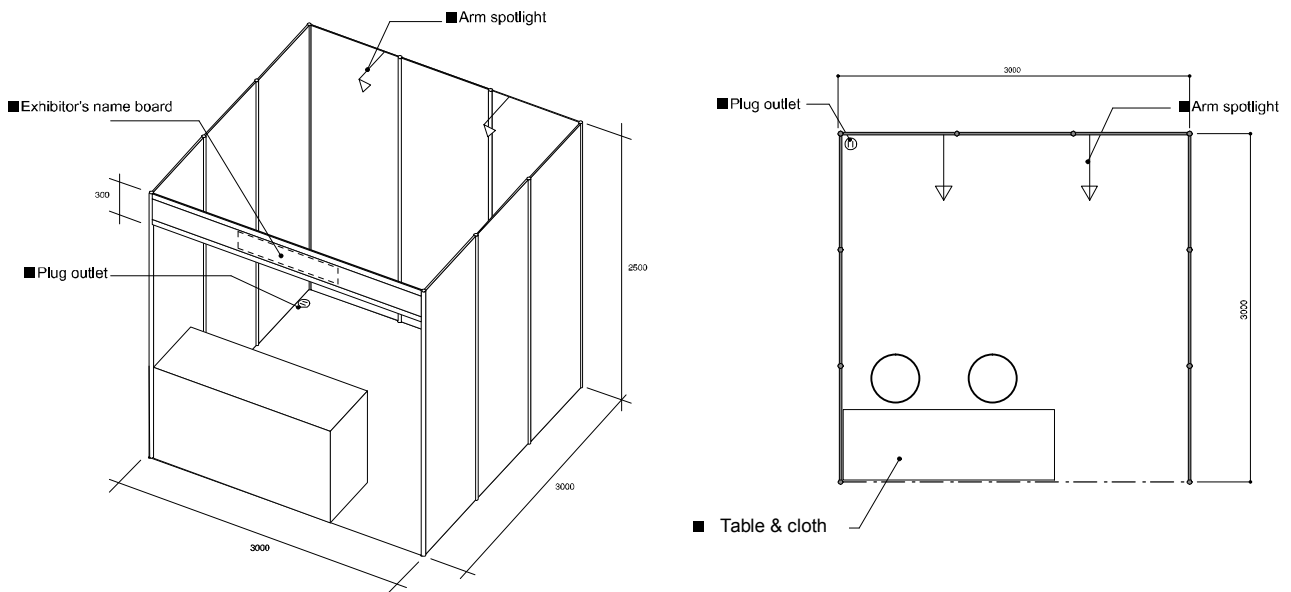

Each booth will be provided with carpet, exhibitors name on the Fascia and:

Shell Scheme (sq. mtr.)	Table	Chair	Spotlight	Elec. Outlet (100V : 500W)
9	1	2	2	2

Table

1 table will be provided with a white cloth and 2 chairs.

Size : W1.8m x D0.9m x H0.7m

Fascia Board

1 Fascia Board with your company name as indicated below will be provided at no extra cost.*

Please order by Form A-3.

Size : 180cm x 25cm

Color : white

Company Name: Black block letters

*To include a company logo in your board, the cost will be charged.

Electric Outlets

All booths are provided with 2 standard Japanese outlets (100V) place at the left corner of your booth.

For special requests, please order by Form A-2.

Electric Power

Electric power capacity is 500W (100V).

If you need more power, the cost will be charged later.

The cost is 5,250 JPY per 500W.

For special requests, please order by Form A-2.

Carpet

Color : Pink (standard color throughout the exhibition area)

Furniture, telephone, and other items.

Please order by Form A-4.

The cost of them will be charged later.

Exhibition of Unauthorized Products

If exhibitors wish to display medical equipment not authorized by Ministry of Health, Labor and Welfare of Japan, a special sign saying that "Displayed products are not for sale and cannot be given out" will be required. Please ask Exhibition Secretariat for details. Please note that unauthorized pharmaceutical drugs cannot be exhibited.

Contact Information

Exhibition Secretariat

Hongo UC Bldg. 4F, 3-35-3 Hongo Bunkyo-ku, Tokyo, 113-0033

FAX: +81-3-3815-2028

Email: apsr-ex@coac.co.jp

FORM A-1 : Badge Request Form

Please return this form to:

Exhibition Secretariat for APSR2006

FAX:+81-3-3815-2028

E-mail: apsr-ex@coac.co.jp

Deadline : October 27, 2006

Exhibitor's name	
Contact Person	
E-mail	

Exhibitor's badge (Free)

Please indicate the number of exhibitor's badge you need.

_____ (# of badges)

FORM A-2 : Electricity Request Form

Please return this form to:

Exhibition Secretariat for APSR2006

FAX:+81-3-3815-2028

E-mail: apsr-ex@coac.co.jp

Deadline : October 27, 2006

Exhibitor's name	
Contact Person	
E-mail	

1. Electricity Request

Item	Rate (JPY, tax inclusive)	Qty	Total (JPY)
Additional plug outlets	3,990 / 2 outlets		
Arm spot (100W)	4,200		
Additional electricity power	5,250/500W	W	
24 hour supply	Contact us	W	
Plug outlet of 200V	Contact us	W	

2. The location of Electrical Outlet

Kindly write down a location for outlets.

If there is no request, the outlets will automatically be placed at the location of "A"

A
Table

FORM A-3 : Fascia Board Order Form

Please return this form to:

Exhibition Secretariat for APSR2006

FAX:+81-3-3815-2028

E-mail: apsr-ex@coac.co.jp

Deadline : October 27, 2006

Exhibitor's name	
Contact Person	
E-mail	

Please tick a check box to order a fascia board.

Fascia Board with Company Name (Free)

Size : 180cm x 25cm

Color : white

Letter : black block letter

Please fill in your company name below and return this form to us.

Exhibitor's Name	
------------------	--

Fascia Board with Company Logo (12,600 JPY)

Please send the data of your company logo to us by e-mail.

After receiving it, we will send you a manuscript.

FORM A-4 : Telephone, LAN and Furniture Order Form

Please return this form to:

Exhibition Secretariat for APSR2006

FAX:+81-3-3815-2028

E-mail: apsr-ex@coac.co.jp

Deadline : October 27, 2006

Exhibitor's name	
Contact Person	
E-mail	

1. Application Form

Item/Service	Description	Rate (JPY, tax inclusive)	Qty	Total (JPY)
Internet line (LAN)	Set-up + 1 line	39,900		
Sub-line	per one line	11,550		
Telephone Line	analog line/ push line	14,700		
Stack Chair	Red	630		
Table	W1.8m x D0.9m x H0.7m	2,100		
Counter	white, W0.9m~	7,875~		
Hanging S-Hook	2 sets, for panel	210		
Green Plant	H150cm	3,990		
White Cloth	For table	945		
Catalogue Stand	self-standing, 6 tiers	5,775		
Small Box	For collecting business cards	1,680		
Bilingual Hostess	Bilingual Staff (Japanese & English)	20,000 / day	days person	

If you need items not listed above, please contact the Exhibition Secretariat.

2. Beverage

If you would like to order beverage, please indicate below. We will contact you later.
Please note that it is not allowed to bring the beverage purchased outside.

Yes: _____

No: _____